

# A systematic study on the improvement of irrigation system with an automatic water flow controller

P.Wilson\*, T.Arun Srinivas and V.Sridevi

Department of Electrical & Electronics Engineering, Jeppiaar Engineering College, Chennai

\*Corresponding author: Email: wilsonjeejpr@gmail.com

## ABSTRACT

In irrigation system, the reduction of the production cost is very essential but it is difficult due to the cost of fertilizers, pesticides and lack of rain water. Using resources properly, the production cost reduction is possible. With this study, the atmospheric temperature, moisture of soil, sun radiation, rainfall and water flow rate are considered to vary the water flow. Solar radiation sensor is used to measure the radiation of the solar. Its Operating Temperature is from 40° to +65° C, Range of measurement is from 0 to 1800 W/ m<sup>2</sup> and Power supply requirement is 5 VDC ± 5 %; 1mA. SHT1x can be used to measure humidity and temperature of the atmosphere. LM 35 can be used to measure the temperature of the atmosphere. This system also uses PIC microcontroller, digital display units and converter circuits.

**KEY WORDS:** Irrigation system, Cost reduction, atmospheric temperature measurement, moisture of soil measurement, flow controller.

## 1. INTRODUCTION

The food is very essential for all the living things in the world. But the production of grains, fruits, vegetables, etc. are reduced due to the production cost. Due to the increasing food production cost, the farmers are not cultivating the food products. Some of the techniques can be used to reduce the production cost of the food. This study helps the farmers to reduce the production cost and how to improve the production of the food. In general, the investment of water is very high during the cultivation. The water cost can be reduced using the smart water pumping system.

Nowadays due to lack of rain water, the underground water is used to cultivate grains. The underground water is taken out with the help of pumps and it is used for agriculture. Here a dedicated system is designed to utilize the ground water effectively for the food cultivation. The effective utilization of the water reduces entire production cost. About 70% of the river and ground water is used for irrigation, ten percentages is used for domestic applications and twenty percentages is used for industry applications.

The dedicated controller uses the humidity sensors, soil moisture sensors, flow sensors, etc. All the sensors are connected to dedicated controller; the controller is designed to control the water flow according to the moisture of the soil.

**Need for soil moisture measurement:** The soil moisture sensor is used to sense the moisture of the soil. The metal spikes act as sensor and the output voltage is obtained from the sensor. The output of the moisture sensor is given to the controller. The controller produces output based on the sensor output. The moisture sensor is very essential for maintaining the land wetly.

### Design of controller:

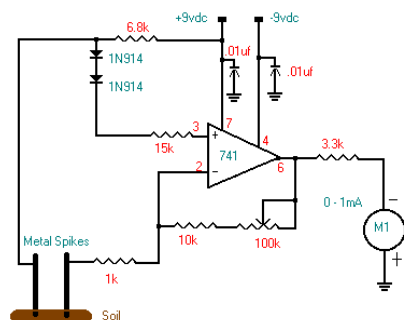

Fig.1. Soil moisture measurement System

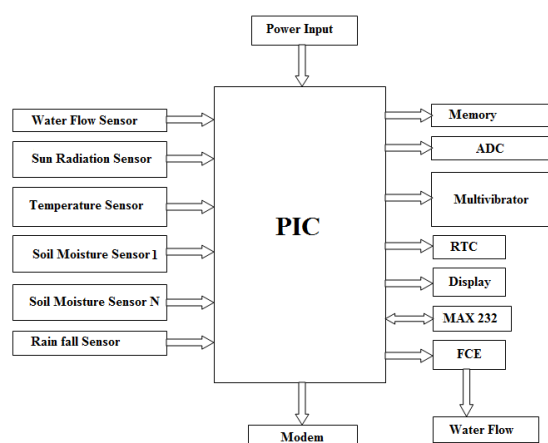
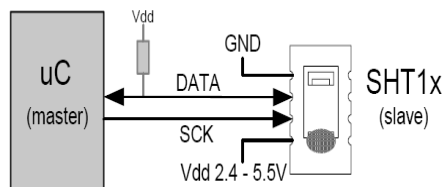

Fig.2. Proposed PIC Controller for Testing Kit

## 2. METHODS AND MATERIALS USED FOR PROPOSED PARAMETER MONITORING SYSTEM

**Water Flow Sensor:** Chrome Magnetic SUS 304 stainless steel water flow switch sensor is used to sense the flow of water. Its input voltage is (0-110) V, Current rating 0.5A, Chrome magnetic SUS Inner Diameter: approx. 18.75mm/0.74 inch, Outer Diameter: approx. 26mm/1 inch and no standby power is required. It operates according to the principle of faradays law. It is made up of stainless steel with carbon steel. The output signal is given to the input of the PIC controller.

**Atmospheric temperature and humidity:** SHT1x can be used to measure humidity and temperature of the atmosphere. This unit comprises with sensing element, signal processing elements and calibrated digital output display. Humidity is measured by a capacitive sensing element and temperature is sensed by temperature sensor. This technology has good reliability, sensitivity and excellent stability. Serial interface unit is used to connect sensor with ADC (Analog to digital convertor). The external disturbances are neglected due to quality of the signal and response speed. The presence of water vapor in the air is called Humidity. Water vapor is invisible because it is in gaseous form. Relative humidity, expressed as a percent, measures the current absolute humidity relative to the maximum (highest point) for that temperature. Specific humidity is a ratio of the water vapor content of the mixture to the total air content on a mass basis.



**Fig.3. Automatic Temperature Measuring Kit**

**Temperature of the Atmosphere:** Temperature can be measured using temperature sensors. To measure the ambient temperature, LM 35 can be used. Solid state technique is used in this sensor to measure the temperature. Thermometers are not used in this study because the output should be the signal to interface with PIC controller. The thermometer does not give us signal output. As LM 35 is made of IC technology, its size is very small and cost less. Precision and accuracy is very high because it does not use any moving part like analog ammeter and analog voltmeter. The measuring range of this meter is -55 degree centigrade to +150 degree centigrade.

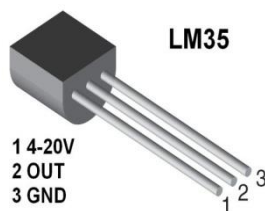

**Fig.4. Thermistor**

### 3. RESULTS AND DISCUSSION OF PARAMETER VARIATIONS

**Radiation and sunshine:** The pyrometer can be used to measure radiation of the sun. The radiation pyrometer measures the temperature above 1200° C. The advantage of this temperature sensor is that it should not be kept in the measuring bath during measurement. If measuring area is very narrow, the temperature measurement is impossible and it can be done using pyrometer. Radiation pyrometer uses long tube with concave lenses to measure temperature.

**Ultraviolet C:** It ranges from 100 to 280nm. The name ultraviolet indicate that the radiation is higher than the frequency of violet light. Atmosphere observes very less violet light from the sun light so it reaches earth.

**Ultraviolet B:** The range from 280 to 315 nm is called as ultraviolet B. The range from 315 to 400 nm is called as

**Ultraviolet A:** The range from 380 to 780nm is visible to naked eye



**Fig. 5. Ultraviolet Sensor System**

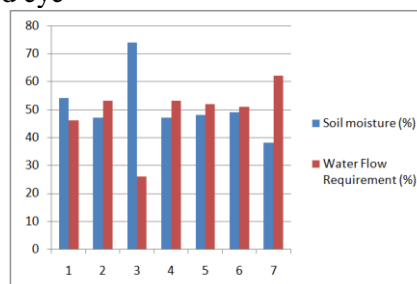

**Fig.6. Bar Diagram for Parameter Monitoring System**

**The Observed Data:****Table.1.Comparison of Temperature, Radiation and Moisture**

<b>Date (10.00am)</b>	<b>Atmospheric Temperature (°C)</b>	<b>Radiation (W/m<sup>2</sup>)</b>	<b>Soil moisture (%)</b>	<b>Rainfall (mm)</b>	<b>Water Flow Requirement (%)</b>
15/01/2016	87	205	54	0	46
16/01/2016	87	416	47	0	53
17/01/2016	85	196	74	0	26
18/01/2016	87	512	47	0	53
19/01/2016	87	218	48	0	52
20/01/2016	87	468	49	0	51
21/01/2016	88	818	38	0	62

**4. CONCLUSION**

This study reveals that the water requirement for irrigation can be varied on the basis of temperature of the atmosphere, moisture of the soil, sun radiation and rain fall. If the water requirement of the irrigation system is varied based on the abovementioned parameters, the cost of the irrigation can be reduced and the efficiency of the irrigation is improved.

**REFERENCES**

Cuihong Liu Wentao Ren Benhua Zhang Changyi LV, The application of soil temperature measurement by LM35 temperature sensors, International conference on Electronic and Mechanical Engineering and Information Technology (EMEIT), 2011.

Hao sipeng Zhang Yangfei Li Xianyun Yuan Yue Sch, of power Electr. Eng, Nanjing Inst. Of Technol, Nanjing, China —Equivalent wind speed model in wind farm dyanamic analysis| 4th International Conference on Electric Utility Deregulation and Restructuring and Power Technologies (DRPT)., 2011.

Hao sipeng Zhang Yangfei Li Xianyun Yuan Yue, The equivalent wind speed model in the wind farm dynamic analysis, Forth international conference on Electric Utility Deregulation and Power Technologies (DRPT)., 2011

Javadi Kia P, Tabatabaee Far A, Omid M, Alimardani R and Naderloo L, Intelligent Control Based Fuzzy Logic for Automation of Greenhouse Irrigation System and Evaluation in Relation to Conventional Systems|in the World Applied Sciences Journal., 6 (1), 2009, 16-23.

Pranita A, Bhosale, Dixit VV, Water Saving-Irrigation Automatic Agricultural Controller, international journal of scientific & technology research, 1(11), 2012.

Singh N, Mohan A, Dept. of Phys, Nehru Coll, Chhibramau —Determination of size and number density of water droplets by the measurement of intensity of scattered light| International Conference on Mathematical Methods in Electromagnetic Theory, MMET 98, 1998

Sulaiman S, Manut A, Nur Firdaus AR, Design, Fabrication and testing of Fringing Electric Field Soil Moisture sensor for wireless Precision Agriculture Applications, International Conference on Information and Multimedia Technology., 2009.